

VW Golf 3 Kitcar



Driver:		Event: Gravel			
Car Nr. : KIT-CAR VWM		Date:			
Engine-Nr: 1 HK 000 VWM		ECU-BOSCH 2.2			
	Front axle			Rear axle	
Suspension					
Spring (N/mm or Type)		300-60-40		300-60-40	
Helper spring (N/mm or Type)		60-60-60		50.60-30	
Type of absorber		Gravel		Gravel	
Absorber adjustment (Z / D)		3/0 - 5/2	3/0 - 5/2	10/8 - 15/10	10/8 - 15/10
Spring travel limiter Ø/length		44	43	40	42
Steering lock / stroke		16/51			
Anti-roll bar (D=mm)		without		Standard	
Level height (see sketch)		210	210	245	245
Length of spring pack		365	365	395	395
Tie rod height (top/below)		10 / 6			
Leading joint (s.sketch)		17mm			
Position of dome plate (see sketch)		0	0		
Castor (°)		4°50'	4°50'		
Camber(°)		-1°20'	-1°20'	-1°20'	-1°20'
Camber disk					
Trace (mm)		0		+4	
Brake					
Brake disk		295x28		265x10	
Caliper		AP 4 Piston		AP 2 Piston	
Master brake cylinder		0,75"		7/8"	
Hand brake cylinder		0,7"			
Brake pad quality		RS 14		RS 4-2	
Clutch					
Clutchdisk		AP stiff 200			
Clutch cylinder		0,75"			
Wheels					
Rim		7x15		7x15	
Tire dimension		205/65x15		205/65x15	
Tire pressure		2,0		2,0	
Transmission		Nr.:VWM		Wheel set: Kit - Car	
Final drive i				4,23	
Differential		Nr.:		Type: Lamella	
Ramp angle		On 30		Off 90	
Friction surfaces per side		6			
Preload (Nm) / Mounting clearance (mm)		160 N/m		0,22	
Weight:		FL	FR	BL	BR



VW Golf 3 Kitcar

Front axle

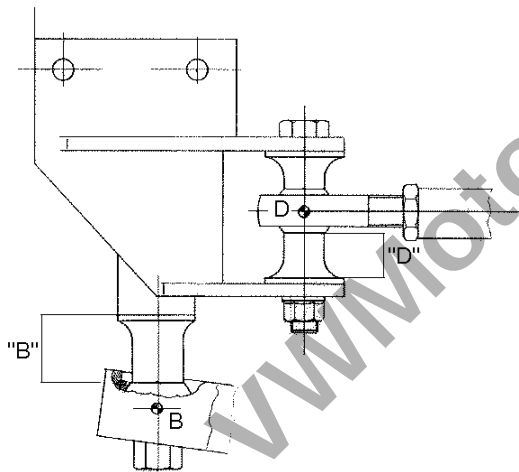
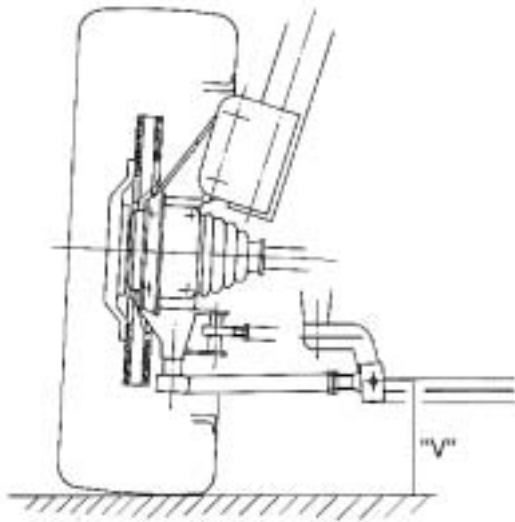

Mounting variation

Position of dome plate left

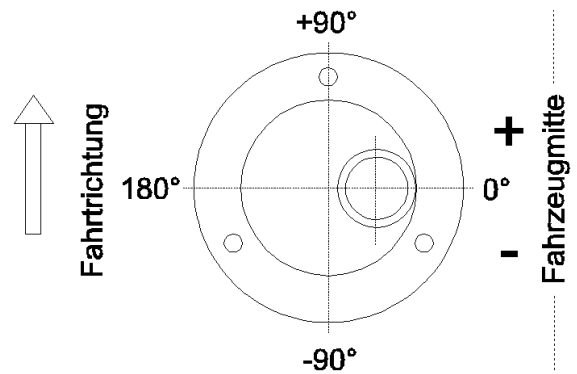

Hinterachse

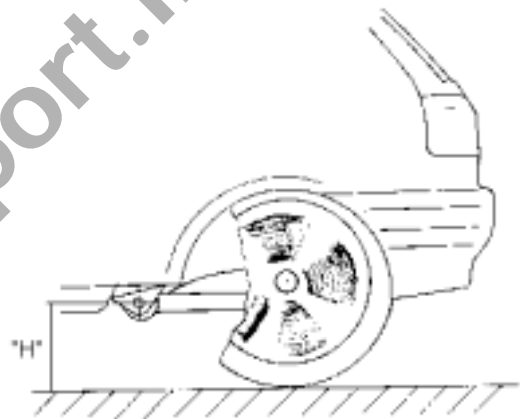

VW Golf 3 Kitcar



VWMotorsport.info